

Work Zone Safety - SynchroGUIDE

Independently proven to improve night-time work zone safety.

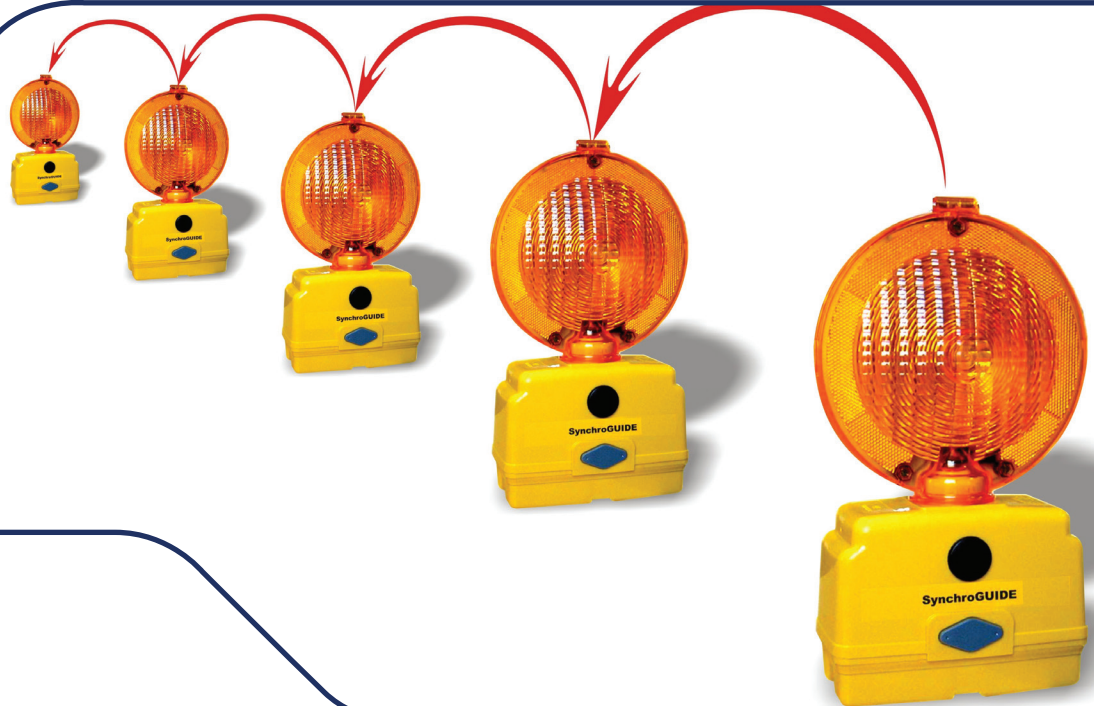

Unique independently field proven technology
Improves approach lane discipline through better driver
recognition of merging taper
2011 ASSHTO TIG Focus technology - worthy of
nationwide consideration
FHWA MUTCD 6F.83 08 compliant
Deploy in any order - no master or slave
Delivers safer driver approach speeds
Offers continual delineation of any taper length or layout
Self certifiably crash compliant when deployed in
accordance with FHWA WZ-54 memorandum

UNIPART
DORMAN

INTELLIGENT ENGINEERING, UNIQUE PEOPLE, WORKING TOGETHER

Work Zone Sequential LED Taper Guide

The SynchroGUIDE lamp series was designed to be a simply deployable low cost counter measure device, which would not only dynamically enhance the visibility of the work zone entrance but at the same time improve driver lane discipline and approach speeds by providing a clear directional guide.

The SynchroGUIDE combines the latest in LED lamp and lens technology with intelligent synchronization wireless communications technology, to improve night-time driver recognition of the merging taper and help meet the challenge of reducing work zone fatalities and secondary effects.

Unlike arrow boards and static lights, the delineation is not spot based but is continual for the entire taper length, a critically important feature during hours of darkness and poor weather conditions where visibility is reduced.

Technology that leads by example

Deploying SynchroGUIDE is a highly visible safety action for your work zone with proven safety benefits and results that can be achieved fast.

Only slightly more costly than conventional warning lights, and with a high return on investment, the technology will engender public support for an easy to understand safety improvement.

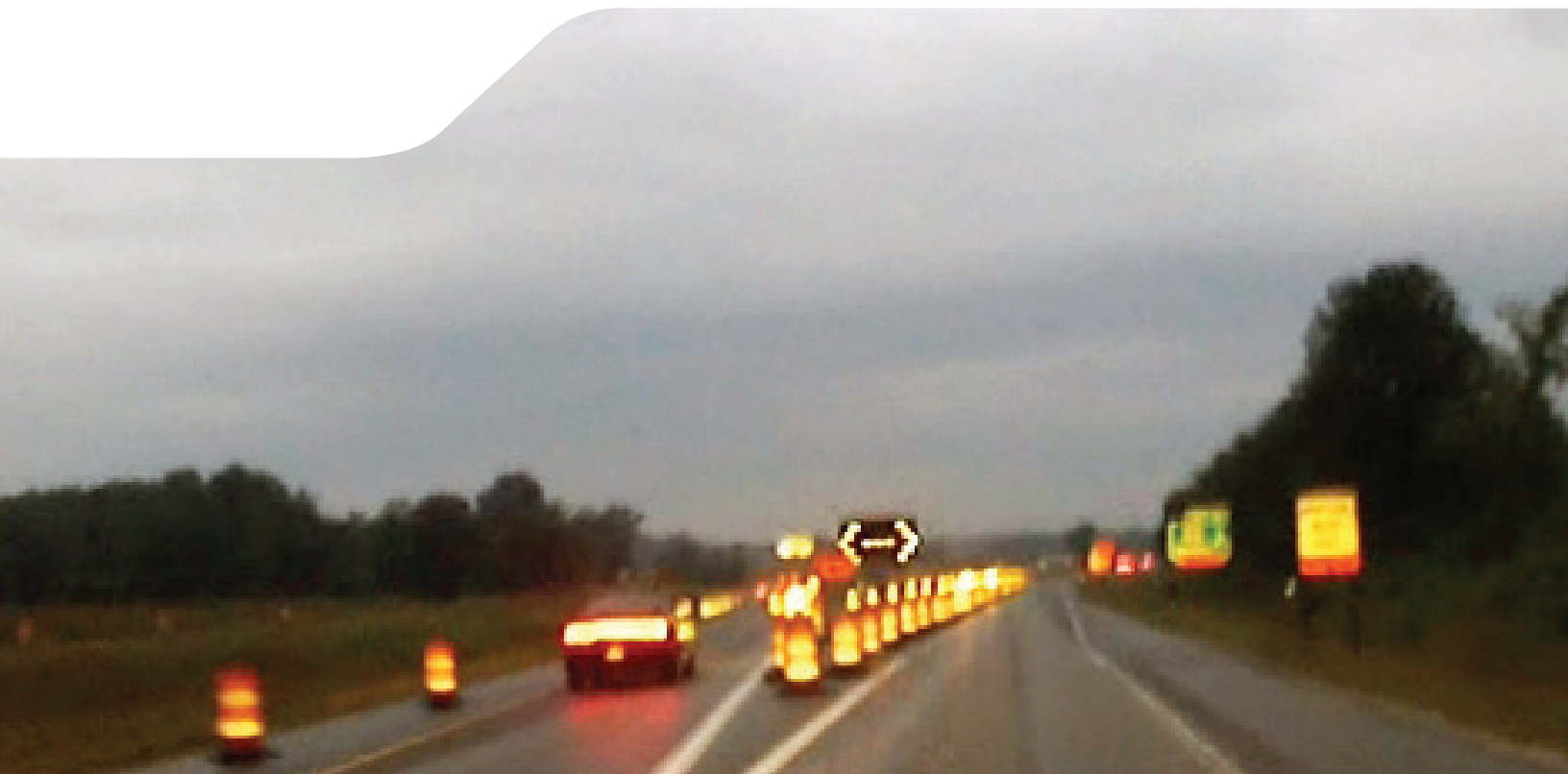

Technical Data

Part Code	BAB6N/AW/P/H/LI					
Display Technology	<p>High Intensity Single Super bright LED. Visible in all lighting conditions, current controlled to maintain a constant light output as the battery Voltage drops.</p> <p>Lamps combine a steady Type C low intensity continuous backlight to illuminate the taper and aid direction indication. This backlight is then overlaid with a sequential Type B high intensity pulse. When the lamps are placed in a line they give the impression of a single light source travelling along the lamps from front to back.</p> <p>Lights must be deployed in accordance with FHWA WZ54 memorandum in order to be crash compliant.</p> <p>High clarity Uni-Directional self colored polycarbonate lens. See operating lifetime table with battery options below.</p>					
Power Supply	Nominal Voltage 6V, Nominal current 41 ma. Each lamp can be fitted with 2 x 6V 25amphr batteries.					
Storage Tray	Designed to store 5 lamps, manufactured from high impact ABS. (Not supplied as standard).					
Flash Rate	60 Pulses per minute.					
Operating Life (2 batteries)	Part Code	Zinc Carbon (6.5 Ah) ANSI 908	Alkaline (12Ah)	Heavy Duty Alkaline (20Ah)	DAAB25 Zinc Air Alkaline	DAAB 50 Zinc Air Alkaline
	270hrs	270hrs	500hrs	830hrs	1040hrs	1870hrs
Independent Data	<p>UKTRL Safety Benefit Analysis 2005 - result - UK highways agency incorporate as standard on all UK High speed works Zones 2006.</p> <p>USA - Missouri SWZDI Cost Safety Benefit Analysis - 2011 - Result - Missouri DOT incorporate as standard on all nighttime interstate work zones and ASSHTO TIG select as focus technology worthy of nationwide consideration.</p>					
Operating Temperature	-29°C to +66°C (-20°F to +150°F). All circuitry within the lamps is fully 'burn in' tested for 24 hrs @ +/- 45°C and moisture protected.					
Weight	Without fastener hardware, the nominal body weight is 0.69kg (1.5lbs). The lamp accepts 2 off ANSI-908, IEC 4R25X, 6 volt batteries. Typically these batteries weigh 450g - 700g (1 - 1.5lbs) - depending upon chemistry type, capacity and manufacturer.					
Mechanical	Polypropylene body giving a very robust case in all extremes of ambient temperature, the lenses are manufactured from high impact polycarbonate. All lamps come with carrying handle fitted as standard. A steel thief proof mounting bolt, not included, passes through body of lamp for fixing to a variety of category I barricade devices.					
Dimensions	See diagram to the right for dimensions.					

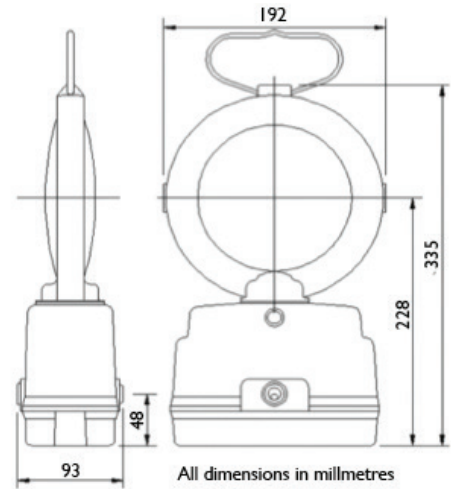

Operation

The lamps may be switched on (by pressing the concealed switch) and placed in line with a spacing between each lamp from 2.2M (7') to 20M (65').

It is essential that all of the opaque lenses face in same direction.

The lamps may be placed with a stagger of up to 2M (6.5').

Each lamp requires two 6v batteries type ANSI 908 or equivalent (not included).

When the lamps are deployed they give the visual impression of a single high intensity 'Type B' light source travelling a clear path along the taper from front to back.

Each lamp has a low output steady 'Type C' backlight to aid direction indication.

About Unipart

The Unipart Group is a leading UK manufacturer, full service logistics provider and consultant in operational excellence.

Operating across a range of market sectors, including automotive, manufacturing, mobile telecoms, rail, retail and technology, Unipart offers a breadth of services to a wide range of blue chip clients internationally.

Unipart Dorman

173 Main Street, Bath,
Ontario, K0H 1G0, Canada

Tel: +1 613 352 3458

Fax: +1 613 352 6845

email: dorman.enquiries@unipartdorman.com

www.unipartdorman.com



Visit www.uniparttrail.com for details
of our Worldwide Regional Offices